

# Hob Mounted Riser Assembly

## YHS001

A heavy-duty bench mounted pre-rinse spray and riser assembly to meet most commercial and institutional kitchen requirements.

Ultra-Rinse pre-rinse trigger spray cleans more efficiently, requiring less water per minute.

### FEATURES

- WELS 6 Star (4 lpm) water efficiency rating
- Dual check valves for backflow protection
- Spring return allows the spray and hose to be pulled into the spraying position and to retract back from the washing area when released

### OPTIONS

- Pot filler for efficiency and maximising workspace has WELS 3 Star (8 lpm) supplied as standard

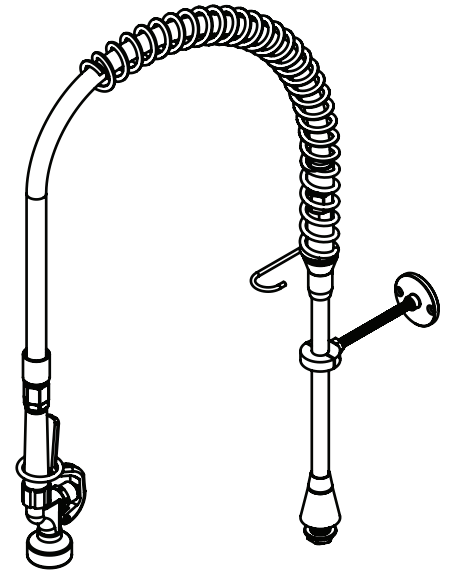

### Product Code

FHS001 with Spring Return



### Technical Information

Inlet Connection	15mm 1/2" BSP
Flow Rate - Gun	4 l/minute
Flow Rate - Pot Filler*	8 l/minute
Recommended Working Pressure	500 kPa
Maximum Operating Temperature	85 °C

\*Supplied standard - also available in 5 Star 6lpm

Note: Must be installed with accessible isolation valve

Enware tapware must be installed in accordance with the provisions of AS/NZS3500 and any relevant local regulations. Installations not complying with AS/NZS3500 may void the product and performance warranty provisions. The performance of Enware AS/NZS 3718 tapware, in many cases, exceeds the plumbing system design requirements of the Plumbing Code of Australia and AS/NZS 3500.

For optimum performance it is recommended that the control valves or taps be turned off when not in use overnight or for long periods. Complete pre-rinse assemblies incorporate a dual check valve for backflow prevention. Lever tapware control incorporate quarter turn non-rising jumper valves.

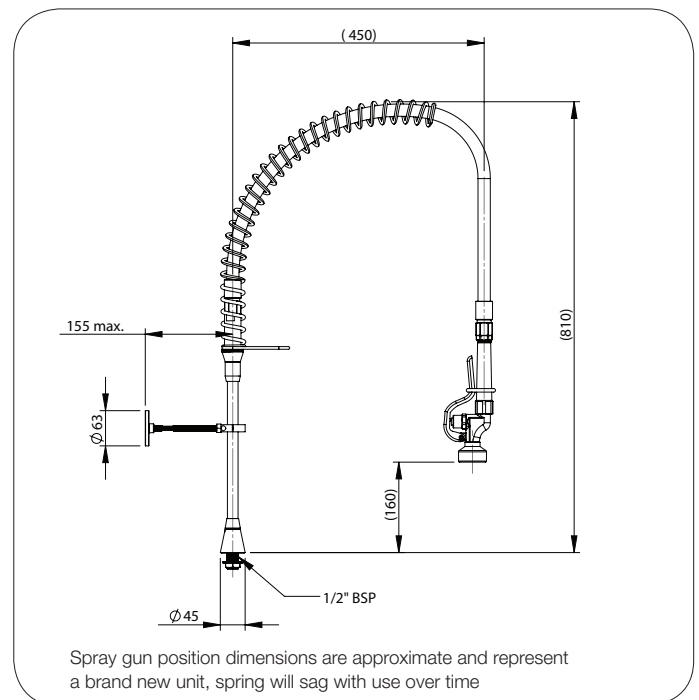

Version: Jun 18